

Model **LC-AW-MKA**

Auto-wash hood

F

Description :

HCE auto-wash, wall-type exhaust hood with adjustable extraction baffles to balance exhaust in the hood. Model LC-AW-MKA.

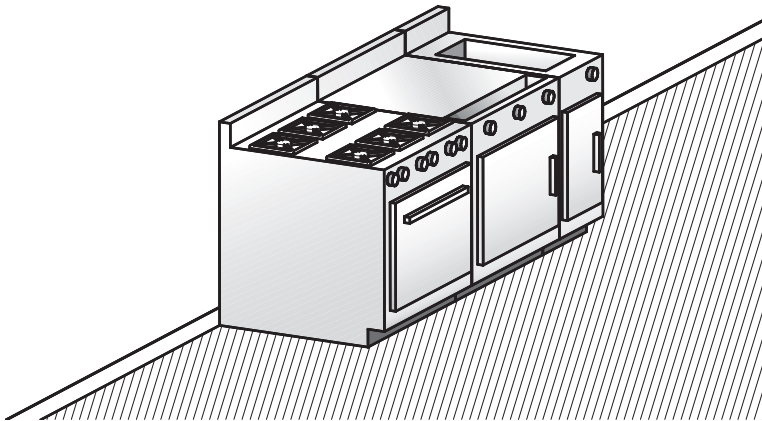
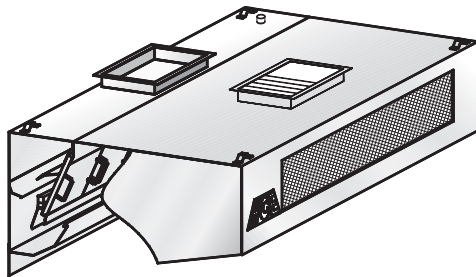

Suggested model

- **Institutional kitchens**
 (hospitals, schools, hotels, restaurant chains, etc.)
- **Steak houses**
- **Low-ceiling kitchens**

Specifications :

- Front supply of tempered make-up air
- Specially designed for low-ceiling kitchens
- Constructed of sturdy 18-gauge (1.2 mm) stainless steel
- Available in lengths of 3' 0" to 16' 0" (914 mm to 4,877 mm)
- Adjustable extraction baffles
- Daily cleaning cycle
- Helps keep extraction baffles clean
- Improves productivity by ensuring efficiency, performance and comfort for the kitchen staff
- Reduces the risk of fire
- Removable, dishwasher-safe extraction baffles
- Easy installation
- Listed 
- Many options available (see reverse)
- Quick delivery

Construction :

Exposed hood surface: type 304 stainless steel with #4 finish (brushed). Non-exposed hood surface: stainless steel with #2B finish, minimum 18-gauge (1.2 mm) thickness. All visible welded joints are polished to match original finish. To meet NFPA- 96 requirements.

Installation :

Suspension (recommended height)

The hood should be installed 6' 6" (1,981 mm) from the floor. Hanging brackets are welded at all four corners.

Important: Horizontal ducts should be sloped toward the collars to prevent water from accumulating in the ducts.

Semi-combustible materials

A clearance of 3" (76 mm) is required when the hood is in contact with semi-combustible materials. As per NFPA-96 standards, a stainless steel spacer will be required.

Enclosure panels (optional) :

The space between the top of the hood and the ceiling may be closed with stainless steel panels in the same finish as the hood.

Electrical :

Junction box and pre-wiring for lighting system may be factory installed if required.

F Auto-wash hood

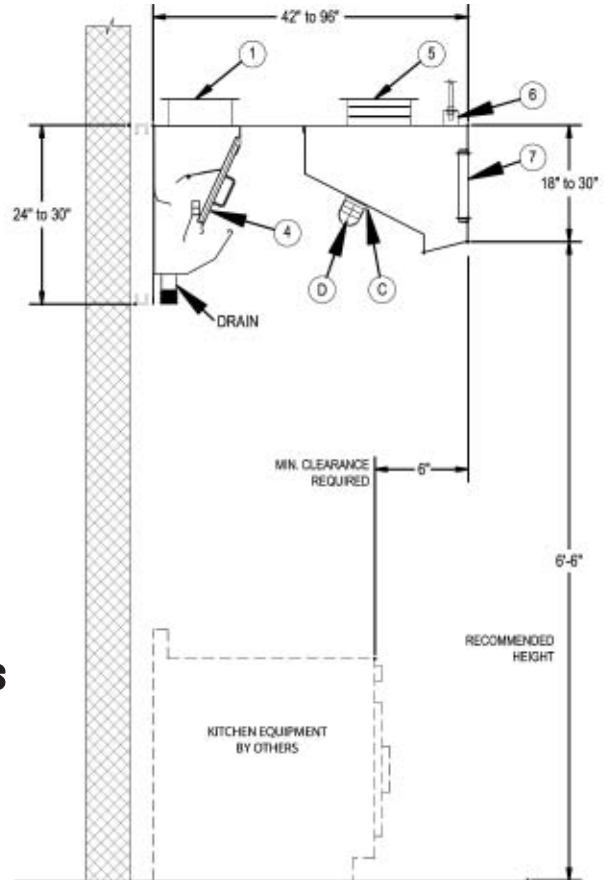
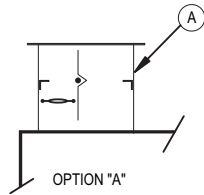
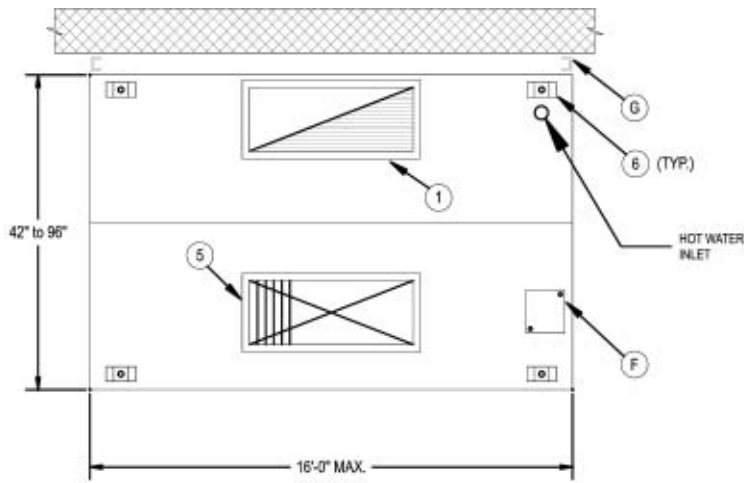

Optional accessories: (see section "K" for details)

A	cULus-listed exhaust collar with fire damper
B	cULus-listed exhaust collar with balancing damper
C	Incandescent lights (Quantity recommended: (1) light per 5 linear feet of hood)
D	Wire guard for incandescent lights
F	Junction box and pre-wiring for lighting
G	3" spacer for clearance to meet NFPA- 96 requirements
H	Enclosure panels, stainless steel with #4 finish, between hood and ceiling
I	PAC-02 programmable control panel
J	End skirts should be used to maximize hood performance

Accessories included:

1	Exhaust collar (3" high)
4	Removable extraction baffles
5	Supply collar with cULus-listed fire damper
6	Hanging brackets
7	Stainless steel supply grid



Model **LC-AW-MKA**

F Auto-wash hood

Length		Exhaust 260 CFM (125 L/S) / Linear Ft. *				Supply		Collar/Opening 12" (305 mm) x _____	
Feet	mm	CFM	L/S	Inches	mm	CFM	L/S	Inches	mm
3'-6"	1068	910	430	10	254	700	330	12	305
4'-0"	1220	1040	490	12	305	800	380	12	305
4'-6"	1372	1170	550	12	305	900	425	14	356
5'-0"	1524	1300	615	14	355	950	450	14	356
5'-6"	1676	1430	675	16	405	1050	500	16	406
6'-0"	1828	1560	735	16	405	1150	545	16	406
6'-6"	1981	1690	800	18	457	1200	570	18	457
7'-0"	2134	1820	860	20	508	1400	660	20	508
7'-6"	2286	1950	920	22	558	1500	710	22	559
8'-0"	2438	2080	980	24	610	1600	755	22	559
8'-6"	2590	2210	1045	24	610	1700	800	24	610
9'-0"	2743	2340	1105	26	660	1800	850	24	610
9'-6"	2895	2470	1165	28	711	1950	920	26	660
10'-0"	3048	2600	1230	28	711	2000	945	28	711
10'-6"	3200	2730	1290	30	762	2150	1015	(2) 16	(2) 406
11'-0"	3352	2860	1350	32	812	2300	1085	(2) 16	(2) 406
11'-6"	3505	2960	1410	(2) 16	(2) 405	2400	1130	(2) 18	(2) 457
12'-0"	3657	3120	1470	(2) 18	(2) 457	2500	1180	(2) 18	(2) 457
12'-6"	3810	3250	1535	(2) 18	(2) 457	2600	1225	(2) 18	(2) 457
13'-0"	3962	3380	1595	(2) 18	(2) 457	2700	1275	(2) 20	(2) 508
13'-6"	4115	3510	1635	(2) 20	(2) 508	2800	1320	(2) 20	(2) 508
14'-0"	4267	3640	1720	(2) 20	(2) 508	2950	1390	(2) 22	(2) 559
14'-6"	4420	3770	1780	(2) 20	(2) 508	3050	1440	(2) 22	(2) 559
15'-0"	4572	3900	1840	(2) 22	(2) 558	3150	1485	(2) 22	(2) 559
15'-6"	4724	4030	1900	(2) 22	(2) 558	3260	1540	(2) 24	(2) 610
16'-0"	4877	4160	1965	(2) 24	(2) 610	3360	1585	(2) 24	(2) 610



	Exhaust VOLUME (CFM /Lin. Ft.)	Internal pressure loss (IN / H ₂ O)	Exhaust VOLUME (L/S per linear metre)	Internal pressure loss (Pa)
Light cooking	175	0,8	270	200
Medium cooking	260	1,0	400	250
Heavy cooking	350	1,65	540	412

See reverse for additional information

F Auto-wash hood

Length		Exhaust 260 CFM (125 L/S) / Linear Ft. *				Hot water flow	
		Exhaust		Collar/Opening 10" (254 mm) x _____		US GPM @ 20 psi	L/m @ 1.4 kg/cm ²
Feet	mm	CFM	L/S	Inches	mm		
3'-6"	1068	910	430	10	254	3,12	11,81
4'-0"	1220	1040	490	12	305	3,51	13,29
4'-6"	1372	1170	550	12	305	3,90	14,76
5'-0"	1524	1300	615	14	355	4,29	16,24
5'-6"	1676	1430	675	16	405	4,68	17,71
6'-0"	1828	1560	735	16	405	5,07	19,19
6'-6"	1981	1690	800	18	457	5,46	20,67
7'-0"	2134	1820	860	20	508	5,85	22,14
7'-6"	2286	1950	920	22	558	6,24	23,62
8'-0"	2438	2080	980	24	610	6,63	25,10
8'-6"	2590	2210	1045	24	610	7,02	26,57
9'-0"	2743	2340	1105	26	660	7,41	28,05
9'-6"	2895	2470	1165	28	711	7,80	29,52
10'-0"	3048	2600	1230	28	711	8,19	31,00
10'-6"	3200	2730	1290	30	762	8,58	32,48
11'-0"	3352	2860	1350	32	812	8,97	33,95
11'-6"	3505	2960	1410	(2) 16	(2) 405	9,36	35,43
12'-0"	3657	3120	1470	(2) 18	(2) 457	9,75	36,91
12'-6"	3810	3250	1535	(2) 18	(2) 457	10,14	38,38
13'-0"	3962	3380	1595	(2) 18	(2) 457	10,53	39,86
13'-6"	4115	3510	1635	(2) 20	(2) 508	10,92	41,33
14'-0"	4267	3640	1720	(2) 20	(2) 508	11,31	42,81
14'-6"	4420	3770	1780	(2) 20	(2) 508	11,70	44,29
15'-0"	4572	3900	1840	(2) 22	(2) 558	12,09	45,76
15'-6"	4724	4030	1900	(2) 22	(2) 558	12,48	47,24
16'-0"	4877	4160	1965	(2) 24	(2) 610	12,87	48,72

* Exhaust for 42" (1,065 mm) and 48" (1,220 mm)-deep hoods. Contact us for assistance to determine the appropriate air volume.

	Exhaust VOLUME (CFM /Lin. Ft.)	Internal pressure loss (IN / H ₂ O)	Exhaust VOLUME (L/S per linear metre)	Internal pressure loss (Pa)
Light cooking	175	0,8	270	200
Medium cooking	260	1,0	400	250
Heavy cooking	350	1,65	540	412

Notes:

- Hot water inlet connection required :
3/4" (19 mm) Ø from 3'6" (1,068 mm) to 16' (4,878 mm).
- Pressure required: 40-70 psi (2,8-4,9 kg/cm²).
- Recommended hot water temperature: 120° to 170°F (49° to 77°C).
- Drain connection: 2" (50 mm) Ø for all hoods.