

ANTI-POLLUTION ECOLOGICAL SYSTEM

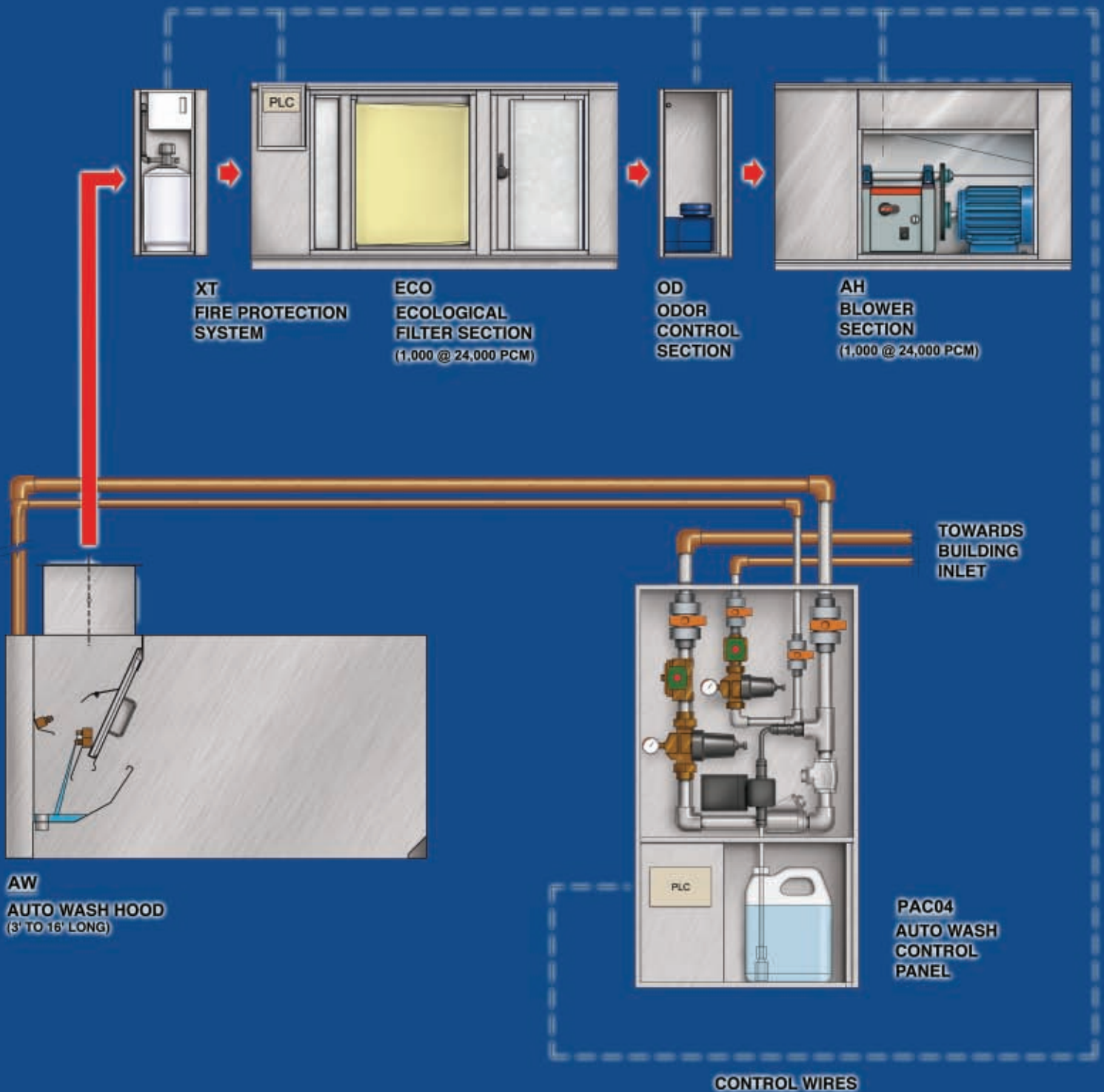

Anti-Pollution Ecological System

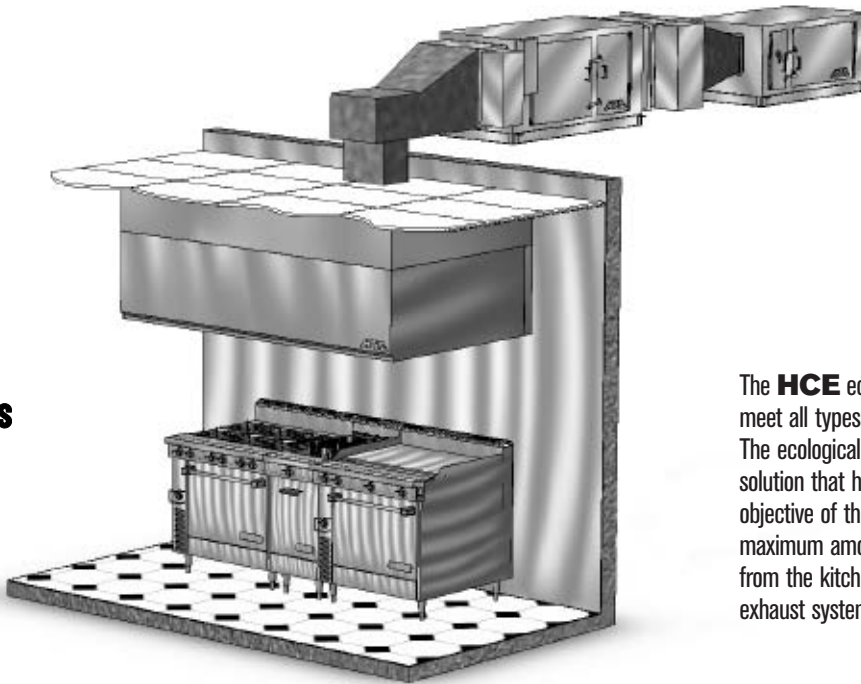

The **HCE** ecological system was designed to meet all types of commercial kitchen installations. The ecological system is an environmentally-friendly solution that helps maintain air quality. The main objective of the ecological system is to extract the maximum amount of grease in the air emanating from the kitchen hood, to then vent it through the exhaust system and out of the building.

Installing an ecological system also has several other advantages:

- The filtered air from the system can be vented to the outside of the building at ground level, generating substantial savings by eliminating the use of a fully welded duct all the way to roof level.
- A fully welded duct between the hood and the filtration section in accordance with NFPA96 and a standard duct as per the National Building Code of Canada between the fan section and the outside of the building.
- 99 % of all grease and smoke from the kitchen hood is extracted by the ecological device.
- Fire risk is greatly reduced.
- Acceptable reduction of cooking odours emanating from the hood.
- The entire unit can be installed in the kitchen ceiling, a service room or on the roof.
- Can be installed in a multi-restaurant project such as a food court.
- Can be installed in a heritage building or a building with a specific architecture.
- cULus listed
- The exterior finish of the unit is stainless steel.

Anti-Pollution Ecological System

I

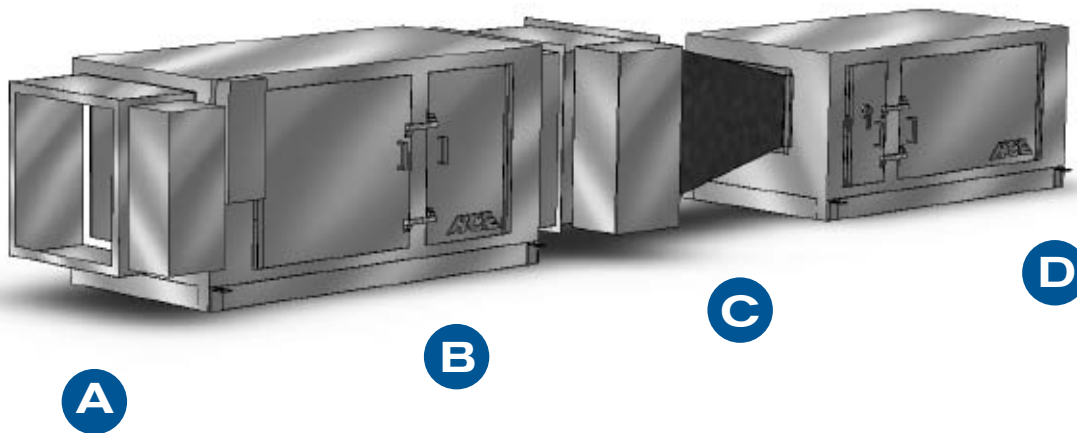

- A** Optional fire protection system section
- B** Filtration section
- C** Optional odour control section
- D** Exhaust blower section

A Optional fire protection system section

The fire protection system section is one of the options available for the ecological device. According NFPA 96. standards, a fire protection system must be installed on an ecological system. There are two possibilities: the installation of an **HCE** fire protection system or the installation of a fire protection system on the job site by a certified company. The fire protection system shall be supplied with a dual micro-switch to connect to the building fire alarm system.

Anti-Pollution Ecological System

B Filtration section

The **HCE ECO** filtration section has a stainless steel casing and steel double inner walls insulated with 1" (25 mm) of ceramic wool. Both walls are 16g thick. Access doors are double-walled, insulated, and hinged. The greasy air from the kitchen hood and its exhaust duct enter the filtration unit to be filtered and degreased.

The filtration section consists of a series of three filter sections, two sections of cULus listed fire dampers and pressure switches to check the condition of the filters in the section.

The three filtration sections are:

- Pleated prefilters 4" (102 mm) thick, 30% ASHRAE 52-76.
- Pocket filters 18" (455 mm) thick, 90% ASHRAE 52-76.
- Absolute filters 12" (300 mm) thick, 99,97% HEPA D.O.P.

1- cULus Class I or II

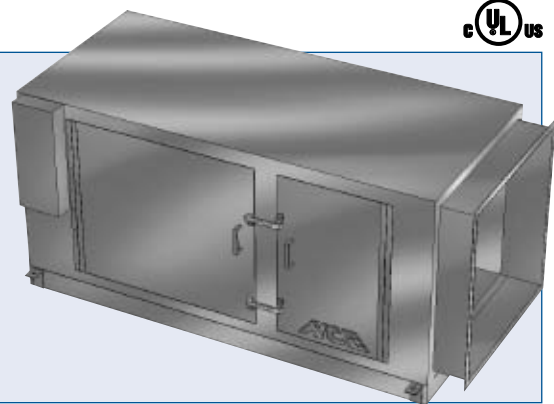

C Optional odour control section

The optional odour control section is installed downstream from the filtration section and consists in injecting liquid **HCE Neutral-Air** in the exhaust flow to neutralize odour causing bacteria. The injection cycle may be permanent or intermittent during kitchen hood and cooking appliance operation. The device is cULus certified with or without the odour control section.

D Exhaust blower section

The outer casing of the **HCE AH** exhaust blower section is stainless steel. It has a perforated galvanized steel double inner wall insulated with 1.5" of acoustic panels. Both walls are 16 g. Access doors are double-walled, insulated and hinged.

The exhaust blower section includes, but is not limited to:

- One double-width, double inlet fan
- One wheel statically and dynamically balanced with back-tilted blades
- Antivibration isolators under the blower and motor
- A prewired magnetic starter to the motor
- A disconnect switch

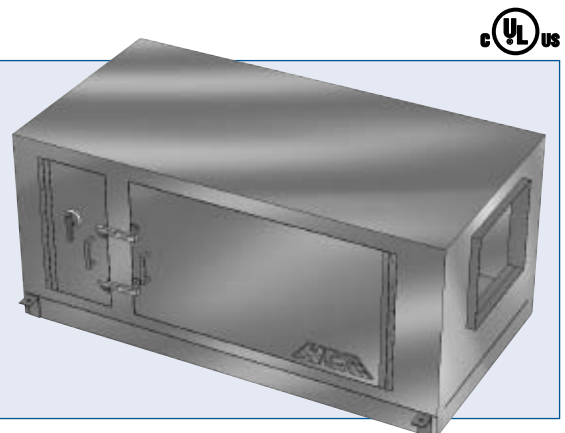



COMPLETE SOLUTIONS

Anti-Pollution Ecological System

