

Model **CM-C**

Hood with cold water mist

H

Description :

HCE island-type exhaust hood, with cold water mist and adjustable extraction baffles to balance exhaust in the hood. Model CM-C.

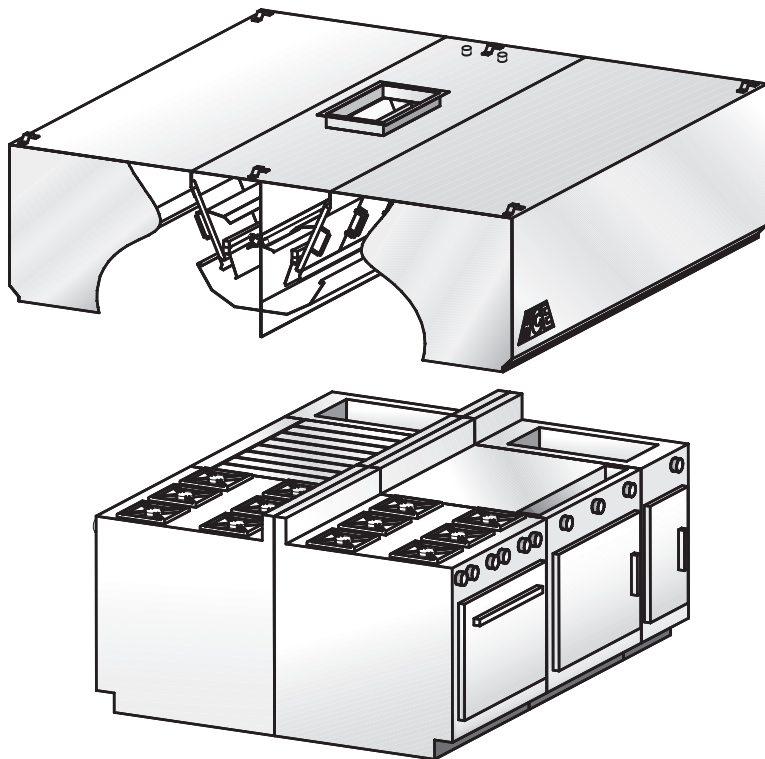

Suggested model

- **Institutional kitchens**
(hospitals, schools, hotels, restaurant chains, etc.)
- **Steak houses**
- **Island application**

Specifications :

- Constructed of sturdy 18-gauge (1.2 mm) stainless steel
- Available in lengths of 3' 0" to 16' 0" (914 mm to 4,877 mm)
- Adjustable extraction baffles
- Helps keep extraction baffles clean
- Reduces the risk of fire
- Removable, dishwasher-safe extraction baffles
- Easy installation
- Listed 
- Many options available (see reverse)
- Quick delivery

Construction :

Exposed hood surface: type 304 stainless steel with #4 finish (brushed). Non-exposed hood surface: stainless steel with #2B finish, minimum 18-gauge (1.2 mm) thickness. All visible welded joints are polished to match original finish. To meet NFPA- 96 requirements.

Installation :

Suspension (recommended height)

The hood should be installed 6' 6" (1,981 mm) from the floor. Hanging brackets are welded at all four corners.

Important: Horizontal ducts should be sloped toward the collars to prevent water from accumulating in the ducts.

Semi-combustible materials

A clearance of 3" (76 mm) is required when the hood is in contact with semi-combustible materials. As per NFPA-96 standards, a stainless steel spacer will be required.

Enclosure panels (optional) :

The space between the top of the hood and the ceiling may be closed with stainless steel panels in the same finish as the hood.

Electrical :

Junction box and pre-wiring for lighting system may be factory installed if required.

H Hood with cold water mist

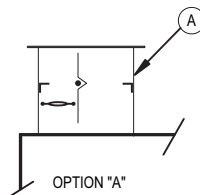
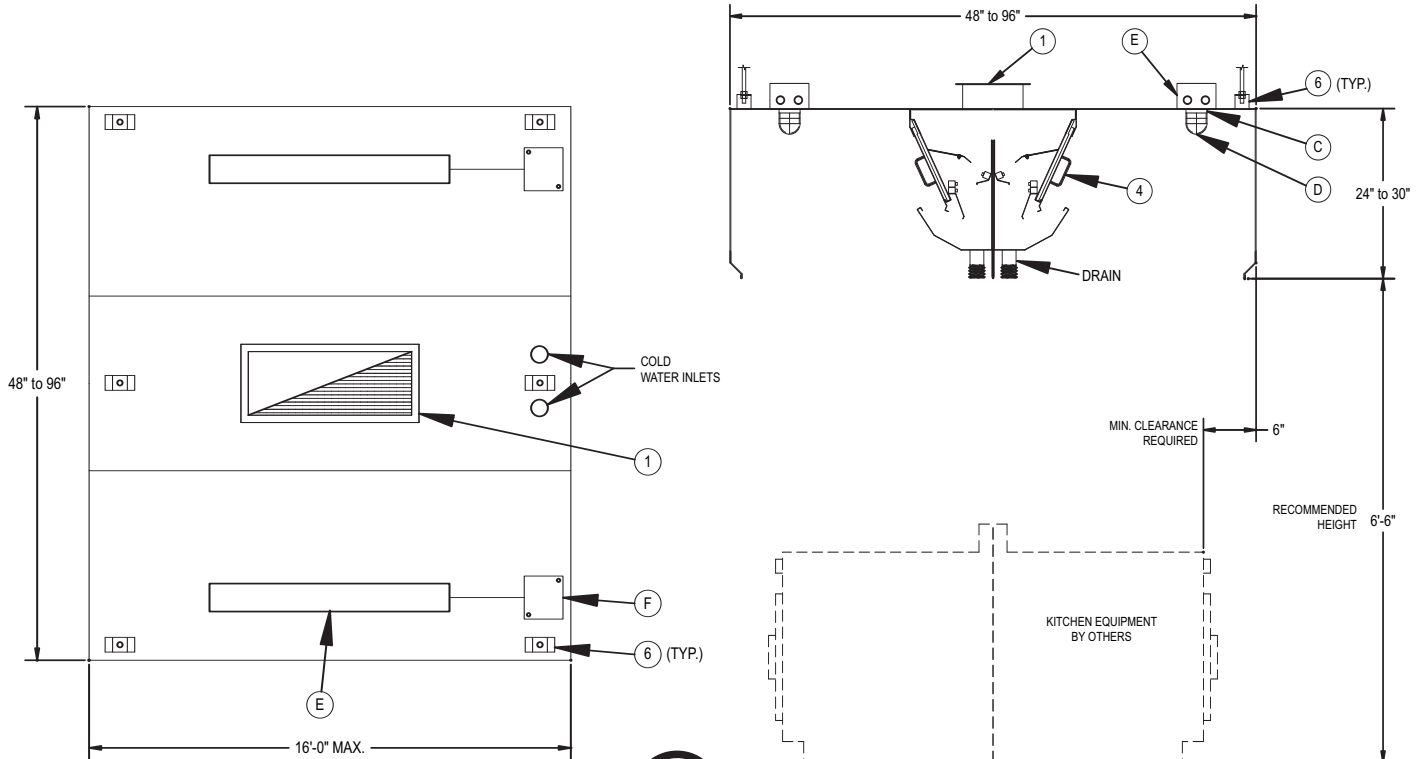

Optional accessories: (see section "K" for details)

A	cULus-listed exhaust collar with fire damper
B	cULus-listed exhaust collar with balancing damper
C	Incandescent lights (Quantity recommended: (1) light per 5 linear feet of hood)
D	Wire guard for incandescent lights
E	36" or 48" fluorescent lights (Quantity recommended: (1) light per 8 linear feet of hood)
F	Junction box and pre-wiring for lighting
H	Enclosure panels, stainless steel with #4 finish, between hood and ceiling
I	PAC-02 programmable control panel
J	End skirts should be used to maximize hood performance

Accessories included:

1	Exhaust collar (3" high)
4	Removable extraction baffles
6	Hanging brackets



Hood with cold water mist

Length		520 CFM (245 L/S) / Linear Ft. *				Cold water flow	
		Exhaust		Collar/Opening 14" (356 mm) x _____		US GPM @ 20 psi	L/M @ 1.4 kg/cm ²
Feet	mm	CFM	L/S	Inches	mm		
3'-6"	1068	1820	860	18	457	0,88	3,32
4'-0"	1220	2080	980	20	508	0,88	3,32
4'-6"	1372	2340	1105	22	558	1,1	4,16
5'-0"	1524	2600	1230	24	610	1,1	4,16
5'-6"	1676	2860	1350	26	660	1,32	4,98
6'-0"	1828	3120	1470	30	762	1,32	4,98
6'-6"	1981	3380	1595	32	812	1,54	5,82
7'-0"	2134	3640	1720	34	864	1,54	5,82
7'-6"	2286	3900	1840	38	965	1,76	6,66
8'-0"	2438	4160	1965	40	1016	1,76	6,66

* Exhaust for 42" (1,065 mm) and 48" (1,220 mm)-deep hoods.
Contact us for assistance to determine the appropriate air volume.

Note:

For CM-C central hoods more than 8' in length, use CM wall-type hoods back to back.



	Exhaust VOLUME (CFM / Lin. Ft.)	Internal pressure loss (IN / H ₂ O)	Exhaust VOLUME (L/S per linear metre)	Internal pressure loss (Pa)
Light cooking	450	0,8	696	200
Medium cooking	520	1,0	800	250
Heavy cooking	700	1,65	1080	412

Notes:

- Cold water inlet connection required :
1/2" (13 mm) Ø from 3'6" (1,068 mm) to 8' (2,438 mm).
- Pressure required: 40-70 psi (2,8-4,9 kg/cm²).
- Drain connection: 2" (50 mm) Ø for all hoods.