

Model **CM-C-MKA**

Hood with cold water mist

H

Description :

HCE island-type exhaust hood, with cold water mist and adjustable extraction baffles to balance exhaust in the hood. Model CM-C-MKA.

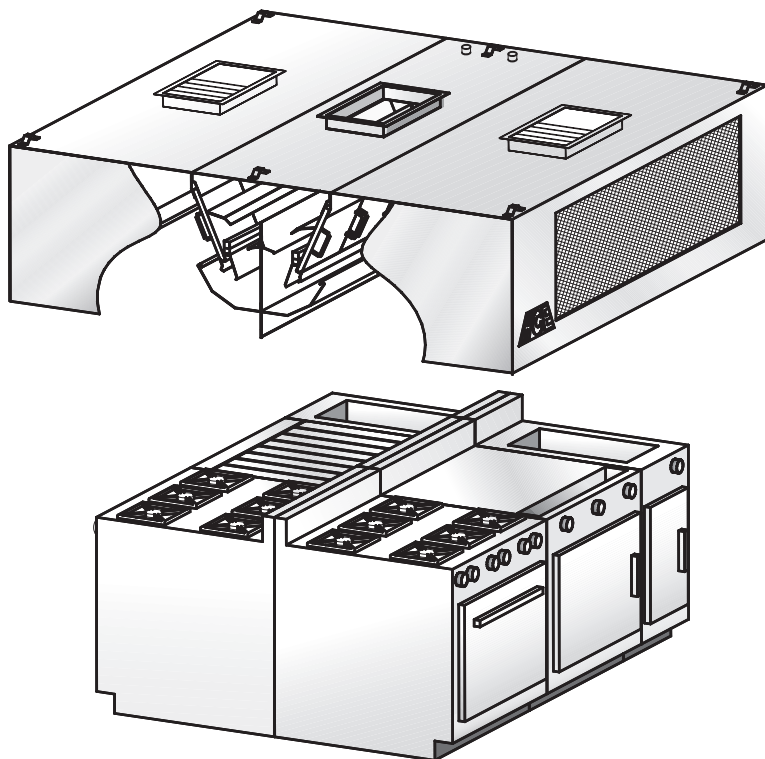

Suggested model

- **Institutional kitchens**
(hospitals, schools, hotels, restaurant chains, etc.)
- **Steak houses**
- **Island application**

Specifications :

- Front supply of tempered make-up air
- Improves productivity by ensuring efficiency, performance and comfort for the kitchen staff
- Constructed of sturdy 18-gauge (1.2 mm) stainless steel
- Available in lengths of 3' 0" to 16' 0" (914 mm to 4,877 mm)
- Adjustable extraction baffles
- Helps keep extraction baffles clean
- Reduces the risk of fire
- Removable, dishwasher-safe extraction baffles
- Easy installation
- Listed 
- Many options available (see reverse)
- Quick delivery

Construction :

Exposed hood surface: type 304 stainless steel with #4 finish (brushed). Non-exposed hood surface: stainless steel with #2B finish, minimum 18-gauge (1.2 mm) thickness. All visible welded joints are polished to match original finish. To meet NFPA- 96 requirements.

Installation :

Suspension (recommended height)

The hood should be installed 6' 6" (1,981 mm) from the floor. Hanging brackets are welded at all four corners.

Important: Horizontal ducts should be sloped toward the collars to prevent water from accumulating in the ducts.

Semi-combustible materials

A clearance of 3" (76 mm) is required when the hood is in contact with semi-combustible materials. As per NFPA-96 standards, a stainless steel spacer will be required.

Enclosure panels (optional) :

The space between the top of the hood and the ceiling may be closed with stainless steel panels in the same finish as the hood.

Electrical :

Junction box and pre-wiring for lighting system may be factory installed if required.

H Hood with cold water mist

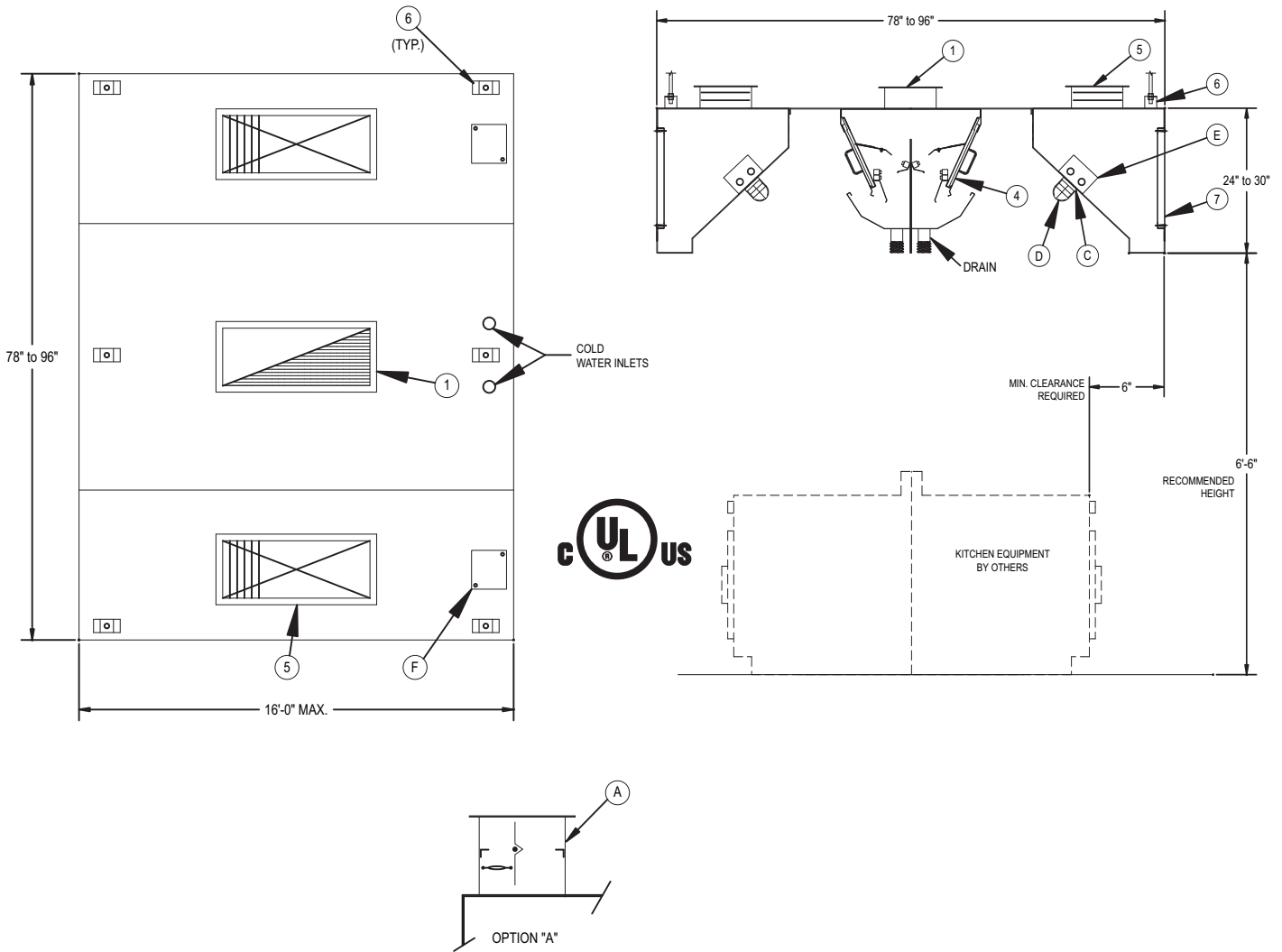

Optional accessories: (see section "K" for details)

A	cULus-listed exhaust collar with fire damper
B	cULus-listed exhaust collar with balancing damper
C	Incandescent lights (Quantity recommended: (1) light per 5 linear feet of hood)
D	Wire guard for incandescent lights
E	36" or 48" fluorescent lights (Quantity recommended: (1) light per 8 linear feet of hood)
F	Junction box and pre-wiring for lighting
H	Enclosure panels, stainless steel with #4 finish, between hood and ceiling
I	PAC-02 programmable control panel
J	End skirts should be used to maximize hood performance

Accessories included:

1	Exhaust collar (3" high)
4	Removable extraction baffles
5	Supply collar with cULus-listed fire damper
6	Hanging brackets
7	Stainless steel supply grid



Model **CM-C-MKA**

H Hood with cold water mist

Length		520 CFM (245 L/S) / Linear Ft. *				Supply		Collar/Opening 12" (305 mm) x _____	
Feet	mm	Exhaust		Collar/Opening 14" (356 mm) x _____		CFM	L/S	Inches	mm
		CFM	L/S	Inches	mm				
3'-6"	1068	1820	860	18	457	1400	660	(2) 12	(2) 305
4'-0"	1220	2080	980	20	508	1650	780	(2) 12	(2) 305
4'-6"	1372	2340	1105	22	558	1800	850	(2) 14	(2) 356
5'-0"	1524	2600	1230	24	610	2050	970	(2) 14	(2) 356
5'-6"	1676	2860	1350	26	660	2250	1060	(2) 16	(2) 406
6'-0"	1828	3120	1470	30	762	2480	1170	(2) 18	(2) 457
6'-6"	1981	3380	1595	32	812	2720	1285	(2) 20	(2) 508
7'-0"	2134	3640	1720	34	864	2950	1390	(2) 22	(2) 559
7'-6"	2286	3900	1840	38	965	3150	1485	(2) 22	(2) 559
8'-0"	2438	4160	1965	40	1016	3350	1535	(2) 24	(2) 610

* Exhaust for 84" (2,130 mm) and 96" (2,440 mm)-deep hood. Contact us for assistance to determine the appropriate air volume.

Note:
For CM-C-MKA central hoods more than 8' in length, use CM-MKA wall-type hoods back to back.



	Exhaust VOLUME (CFM / Lin. Ft.)	Internal pressure loss (IN / H ₂ O)	Exhaust VOLUME (L/S per linear metre)	Internal pressure loss (Pa)
Light cooking	450	0,8	696	200
Medium cooking	520	1,0	800	250
Heavy cooking	700	1,65	1080	412

See reverse for additional information



Hood with cold water mist

Length		520 CFM (245 L/S) / Linear Ft. *				Cold water flow	
		Exhaust		Collar/Opening 14" (356 mm) x _____		US GPM @ 20 psi	L/M @ 1.4 kg/cm ²
Feet	mm	CFM	L/S	Inches	mm		
3'-6"	1068	1820	860	18	457	0,88	3,32
4'-0"	1220	2080	980	20	508	0,88	3,32
4'-6"	1372	2340	1105	22	558	1,1	4,16
5'-0"	1524	2600	1230	24	610	1,1	4,16
5'-6"	1676	2860	1350	26	660	1,32	4,98
6'-0"	1828	3120	1470	30	762	1,32	4,98
6'-6"	1981	3380	1595	32	812	1,54	5,82
7'-0"	2134	3640	1720	34	864	1,54	5,82
7'-6"	2286	3900	1840	38	965	1,76	6,66
8'-0"	2438	4160	1965	40	1016	1,76	6,66

* Exhaust for 42" (1,065 mm) and 48" (1,220 mm)-deep hoods.
Contact us for assistance to determine the appropriate air volume.



Notes:

- Cold supply inlet connection required :
1/2" (13 mm) Ø from 3'6" (1,068 mm) to 8' (2,438 mm).
- Pressure required: 40-70 psi (2,8-4,9 kg/cm²).
- Drain connection: 2" (50 mm) Ø for all hoods.